

# CM2824E182R-10

**UNCONTROLLED DOCUMENT**

**PHYSICAL DIMENSIONS:**

A	7.50	[.295]	+	MAX.
A <sub>1</sub>	9.00	[.354]	+	0.40 [.016]
B	5.50	[.217]	+	MAX.
C	3.80	[.150]	+	MAX.
C <sub>1</sub>	4.90	[.193]	+	MAX.
D	2.54	[.100]	+	0.10 [.004]
T <sub>1</sub>	1.75	[.069]	+	TYP.
T <sub>2</sub>	0.50	[.020]	+	0.10 [.004]
T <sub>3</sub>	0.30	[.012]	+	0.10 [.004]
WEIGHT/1000	0.28	kgs		[.62 Lbs]

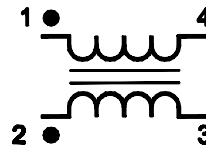
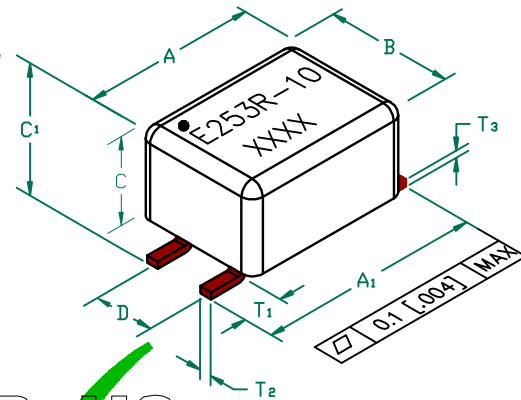

ELECTRICAL SPECIFICATION @ 25°C  
OPERATING TEMPERATURE RANGE: -40°C TO +125°C

PARAMETER SYMBOL	REQUIREMENTS		
	MIN	TYP	MAX
Z SPEC @ 100 MHz	1,350	1,800	2,250
DCR (Ω)			0.26
I (mA)			800

- NOTES: UNLESS OTHERWISE SPECIFIED
1. TAPED AND REELED ON 13" REELS, 1500 PCS/REEL.
  2. OPEN BOTTOM CONSTRUCTION.
  3. COMPONENTS SHOULD BE ADEQUATELY PREHEATED BEFORE SOLDERING.

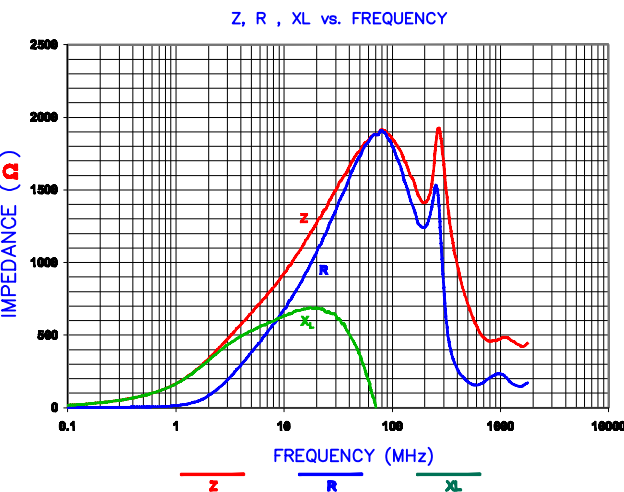
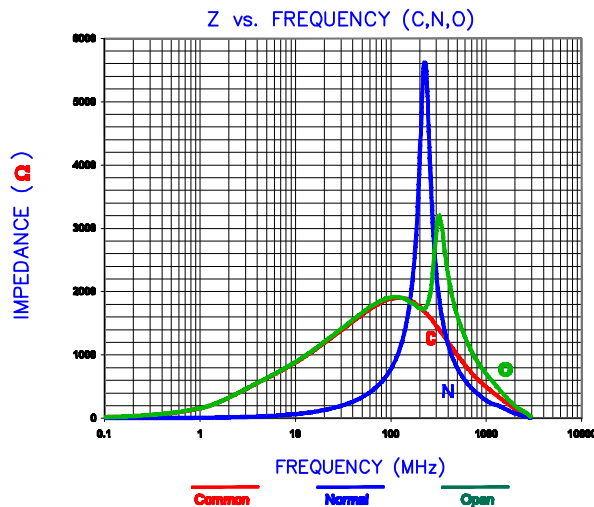

LAND PATTERNS FOR REFLOW SOLDERING

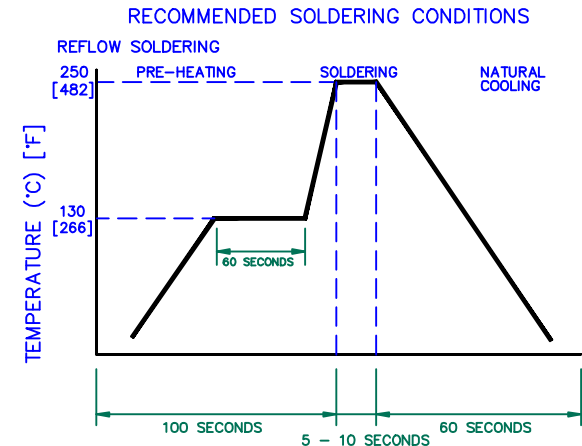
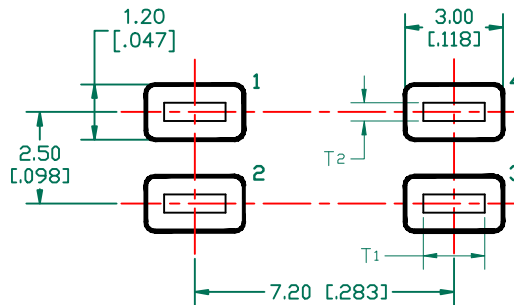

DIMENSIONS ARE IN mm [INCHES].				THIS DOCUMENT CONTAINS INFORMATION WHICH IS PROPRIETARY AND CONFIDENTIAL TO STEWARD. NO PRODUCTION OR PUBLICATION OF THIS DOCUMENT IN WHOLE OR IN PART SHALL BE MADE WITHOUT WRITTEN AUTHORIZATION FROM STEWARD.			
				PROJECT/PART NUMBER:	REV	PART TYPE:	DRAWN BY:
				CM2824E182R-10	B	COMMON MODE CHOKE	JRK
B	UPDATE COMPANY LOGO	11/20/07	JRK	DATE:	05/16/06	SCALE:	NTS
A	ORIGINAL DRAFT	05/16/06	JRK	CAD #		TOOL #	
REV	DESCRIPTION	DATE	INT	CM2824E182R-10-B			2 of 2